

A Nonlinear Model Library for Dynamics and Control

John D. Hedengren
john@hedengren.net

The purpose of this library is to provide researchers and industrial vendors with benchmark models of differential and algebraic (DAE) equations. These benchmark models can be used to demonstrate model reduction, simulation, estimation, control, fault detection, etc.

Including the model in the nonlinear database allows other researchers to more easily reproduce the results for further enhancement. The database also serves as a resource for researchers who wish to publish a series of papers, each with a different application. This demonstrates the interdisciplinary potential and gives additional credibility to the proposed applications. With a standard set of test models, the example problems are not over-simplistic or fabricated for problem specific strengths. These applications can demonstrate the performance across diverse disciplines ranging from traditional to emerging areas.

The collection can also be useful to industrial practitioners as a valuable starting point for the development of more sophisticated models for simulation, estimation, and control. Often the greatest obstacle to nonlinear control is the development of an accurate and robust model of the process. The starting point of a simple model serves as a framework to build models and fit parameters to actual process data.

This nonlinear model database is an attempt to create a collaborative collection where process models can be documented and shared. However, there are several obstacles that must be overcome before a model can be released. Copyright restrictions, proprietary

information, and the desire to “clean up the model” are some of the more common reasons that prevent model submission. A number of model descriptions credit the people involved in preparing and submitting the models. Citations are also noted for models that have appeared in publications. Authors are also encouraged to reference this library in their publication to encourage further model submissions.

The model database was formerly hosted on the University of Texas Chemical Engineering web-site until 2007. The current set can be obtained at:

<http://www.hedengren.net/research/models.htm>

Currently, all models are written in MATLAB. These models can easily be transformed to other differential and algebraic (DAE) modeling languages such as APMonitor, gProms, or Modelica. A comparison of modeling language syntax for a simple gravity drained water tank is shown at:

<http://apmonitor.ath.cx/compare.htm>

Table I is a description of some of the models in the database. The ID column in Table I is the unique identifier and contains a hyperlink to download the model. The file will download as model[ID].zip and will contain both the model and supporting documentation. The model size refers to the number of differential and algebraic equations that are solved implicitly. Explicit intermediate variables or algebraic outputs are excluded from the count. “UR” indicates models that have unstable regions. For the continuously stirred tank reactors (CSTRs), the instability is caused by exothermic reaction that causes reaction runaway. “NL” indicates models that are nonlinear. While most of the models are nonlinear, there are four models where linear differential equations allow a $\dot{x} = Ax + Bu$ state space representation.

Table I: Models in the Collection

ID	Description	Size	UR	NL
1	CSTR with jacket dynamics	2	v	v
2	CSTR with jacket dynamics and 4 species	4	v	v
3	CSTR with jacket dynamics and 3 species	3	v	v
4	2 CSTRs in series	6	v	v
5	2 CSTRs in series with jacket dynamics	4	v	v
6	Inverted pendulum	2	v	v
7	Solar collector	41		
8	Distillation column 1	32		v
9	Spring	2		
10	Continuously stirred tank reactor	4	v	v
11	Cruise control 1	1		
12	Cruise control 2	2		v
13	Distillation column 2	32		v
14	Distillation column 3	64		v
15	Underwater vehicle	6		v
16	Water tank	1		v
17	Dual string kite model	4	v	v
18	Distillation column with enthalpy equation	204		v
21	Type-I diabetic blood glucose control	3		v
22	Yeast fermentation bioreactor 1	7		v
23	Electric vehicle with a DC motor	7		
24	Yeast fermentation bioreactor 2	2		v
25	Polyethylene reactor	7	v	v

The nonlinear model database includes chemical reactors, binary distillation columns, and simple mechanical systems. The complexity of the models range from a simple ODE model with 1 input and 1 state to a large

DAE model with 2 inputs and 125 states. Most of the models are taken from published articles. Most of the models have a step response driver where the model response is computed with a MATLAB integrator for an example simulation.

Below is a summary and discussion of some selected models in the library.

Model 1 - CSTR

The CSTR model with A->B exothermic reaction is the most popular model in the database. It is a standard model that has been used in reaction engineering textbooks, simulation and control research, and demonstrations for industrial software.

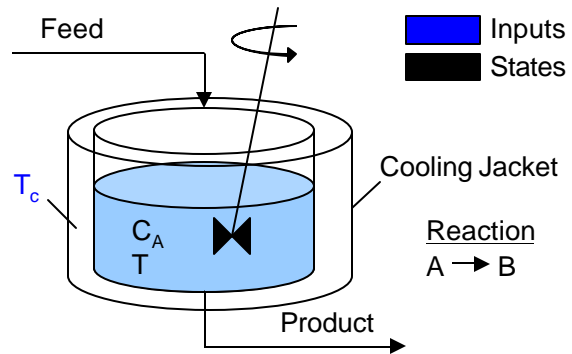

Figure 1. The most popular model in the collection: Continuously stirred tank reactor (CSTR) with A->B exothermic reaction.

Table II. Variables in CSTR Model

T_c	Cooling water temperature (K)
c_a	Concentration of species A (mol/m ³)
T	Reactor temperature
q	Volumetric flowrate (m ³ /sec)
V	Reactor volume (m ³)
ρ	Density of A-B mixture (kg/m ³)
C_p	Heat capacity of A-B mixture (J/kg-K)
ΔH	Heat of reaction for A->B (J/mol)
E/R	Activation energy in the Arrhenius

	Equation (J/mol) / Universal Gas Constant (8.31451 J/mol-K)
k_0	Pre-exponential factor (1/sec)
UA	Overall Heat Transfer Coefficient (W/m ² -K) * Area (m ²)
C_{af}	Feed Concentration (mol/m ³)
T_f	Feed Temperature (K)

Table III: Equations in CSTR Model

Species balance for component A:

$$V \frac{\partial c_a}{\partial t} = q(C_{af} - C_a) - k_0 \exp\left(-\frac{E}{RT}\right) VC_a$$

Energy balance:

$$A = \Delta H k_0 \exp\left(-\frac{E}{RT}\right) VC_a$$

$$B = UA(T_c - T)$$

$$rC_p V \frac{\partial T}{\partial t} = rC_p q(T_f - T) + A + B$$

These model equations are translated to a model function in MATLAB (see file cstr1.m). The model function returns the state derivatives as a function of the current time (t) and states (x). A global variable (u) is used to provide input changes to the temperature of the cooling jacket.

Table IV: CSTR Model in MATLAB

```
function xdot=cstr1(t,x)
global u
```

```
% T of cooling jacket (K)
Tc = u;
% Conc in CSTR (mol/m^3)
Ca = x(1,1);
% Temperature in CSTR (K)
T = x(2,1);
% Flowrate (m^3/sec)
q = 100;
% Volume of CSTR (m^3)
V = 100;
% Density (kg/m^3)
rho = 1000;
```

```
% Heat capacity of A-B
Mixture (J/kg-K)
Cp = .239;
% Heat of reaction for A->B
(J/mol)
mdelH = 5e4;
% E = Arrhenius Equation
(J/mol)
% R = Univ Gas Constant
EoverR = 8750;
% Pre-exponential factor
(1/sec)
k0 = 7.2e10;
% U - Heat Trans Coeff
(W/m^2-K)
% A - Area (m^2)
UA = 5e4;
% Feed Conc (mol/m^3)
Caf = 1;
% Feed Temperature (K)
Tf = 350;
```

```
% Compute xdot:
```

```
xdot(1,1) = (q/V*(Caf - Ca)
- k0*exp(-EoverR/T)*Ca);
```

```
xdot(2,1) = (q/V*(Tf - T) +
mdelH/(rho*Cp)*k0*exp(-
EoverR/T)*Ca +
UA/V/rho/Cp*(Tc-T));
```

These model equations are solved in MATLAB with a numerical integrator. In this case ode15s is used to solve the differential equations over a 5 second horizon. The jacket temperature is stepped from 300 K to 290 K. The cooling of the reactor jacket results in a decrease in reactor temperature and an increase in the concentration of species A. The results are displayed in two plots of the temperature and reactor concentration (see file step.m).

Table V: CSTR Model Step in MATLAB

```
% Step test for Model 1
CSTR
global u
```

```

% Initial Conditions-States
Ca_ss = 0.87725294608097;
T_ss = 324.475443431599;
x_ss = [Ca_ss;T_ss];

% Initial Condition-Control
u_ss = 300;

% Open Loop Step Change
u = 290;

% Final Time (sec)
tf = 5;

[t,x] = ode15s('cstr1',[0
tf],x_ss);

% Parse out the state
values
Ca = x(:,1);
T = x(:,2);

% Plot the results
figure(1);
plot(t,Ca);

figure(2)
plot(t,T);

```

The model has two states: the concentration of A and the temperature of the reaction vessel liquid. The manipulated variable is the jacket water temperature. At a jacket temperature of 305K, the reactor model has an oscillatory response. The oscillations are characterized by reaction run-away with a temperature spike. When the concentration drops to a low value, the reactor cools until the concentration builds and there is another run-away reaction.

Model 3 – CSTR with Intermediate Species

Models 1-5, 10 are all variations of the CSTR model. Model 3 in particular, has a reaction

intermediate (B). There is an additional equation and variable to account for the intermediate reaction step.

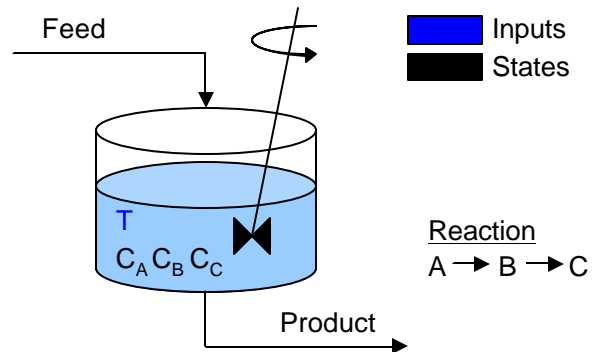

Figure 2. A variation of the CSTR model with an intermediate species (B).

Model 8 - Binary Distillation Column with 30 trays (cyclohexane n-heptane)

Distillation column models are generally good test models for nonlinear model reduction and identification. The concentrations at each stage or tray are highly correlated. The dynamics of the distillation process can be described by a relatively few number of underlying dynamic states. Several publications have included this model as an example application. One in particular is:

Hahn, J. and T.F. Edgar, An improved method for nonlinear model reduction using balancing of empirical gramians, *Computers and Chemical Engineering*, 26, pp. 1379-1397, (2002)

This plot shows the system response after a step change in the reflux ratio from 3.0 to 1.5. Each trajectory represents the mole fraction of cyclohexane at each tray. The top reflux material becomes less pure (more n-heptane) due to the increased draw from the top of the column.

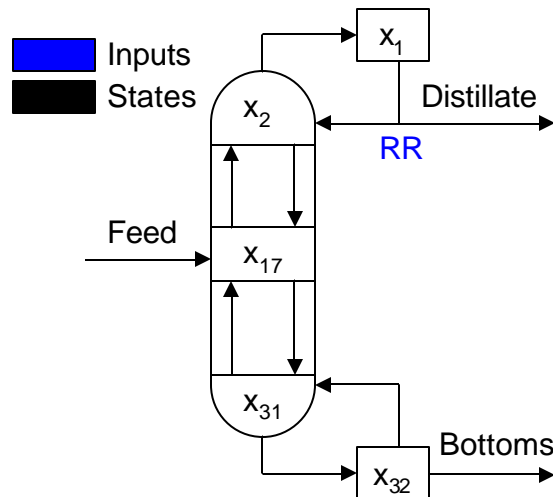

Figure 3a. Distillation column model diagram.

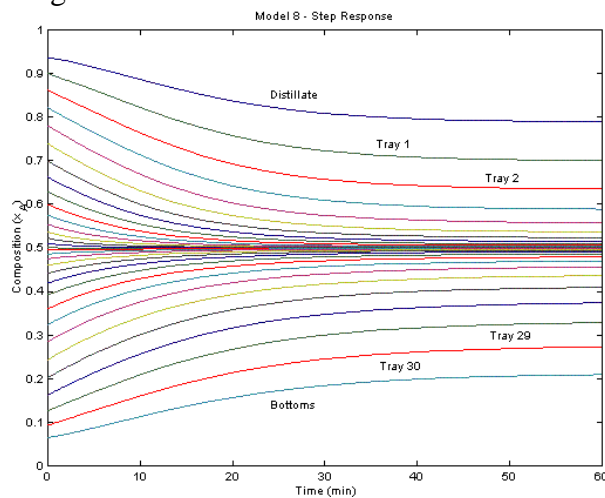

Figure 3b. Distillation column tray concentration profiles after a decrease in the reflux ratio.

Model 12 - Cruise Control with Disturbance

This simple mechanical model is of an object that is seeking to maintain constant speed while subject to disturbances. In this case, the disturbance is the incline or decline angle.

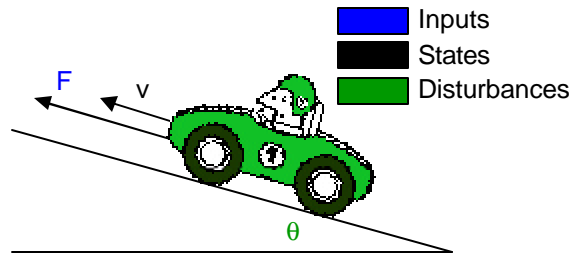

Figure 4. Simple force balance for an object in motion.

Model 16 - Gravity Drained Water Tank

This gravity drained water tank was a control experiment for Tom Edgar's undergraduate control course. The students had to perform experiments to determine the process time constant and tune a PID controller. The nonlinear model gave excellent predictions of level (or volume) and was used to demonstrate the advantage of model predictive control (MPC) over PID control for level control.

The trend shows the inlet valve 80% open for 60 seconds. The volume reaches 1400 mL before the inlet value is shut and the tank drains.

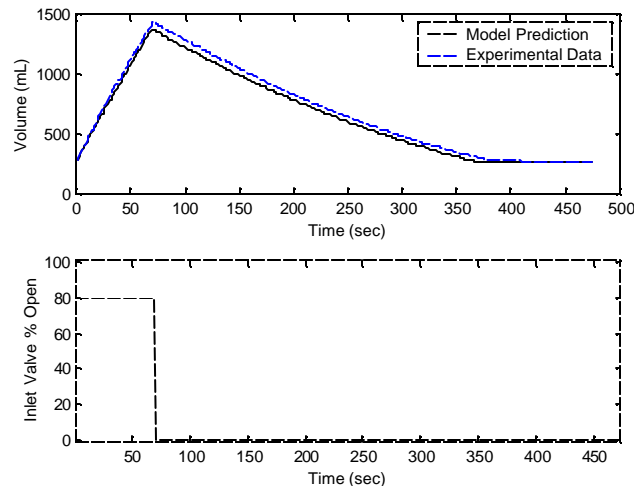

Figure 5. Model and experimental data for a gravity drained water tank.

Model 21 - Human Blood Glucose Model for Insulin Control - Type I Diabetes

This model is combined from two related papers:

S. M. Lynch and B. W. Bequette, Estimation-based Model Predictive Control of Blood Glucose in Type I Diabetes: A Simulation Study, Proc. 27th IEEE Northeast Bioengineering Conference, IEEE, 2001.

and

S. M. Lynch and B. W. Bequette, Model Predictive Control of Blood Glucose in Type I Diabetics using Subcutaneous Glucose Measurements, Proc. ACC, Anchorage, AK, 2002.

It is a simple three state model that effectively describes blood glucose and insulin dynamics. The three states are plasma glucose concentration (mmol/L), plasma insulin concentration (mU/L) in remote compartment, and plasma insulin concentration (mU/L). The principal disturbance variable is the glucose input.

Model 22 - Yeast Fermentation Bioreactor

Zoltan Nagy contributed this model of a continuous plug flow fermentation reactor. Oxygen solubility is a function of the minerals that are present in solution.

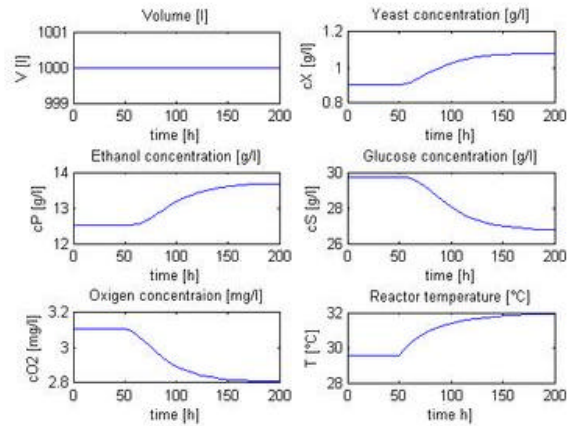

Figure 6. Results from a simulation of the yeast fermentation bioreactor.

Model states include reactor volume, temperature, yeast, ethanol, glucose, and oxygen concentrations. Although the model is shown as a continuous process, minor modifications transform the model into a semi-batch process more commonly found in corn-feedstock industrial ethanol production.

Individuals can make this collection better by submitting models or offering improvements to the current set. The contributions of Matthew Tenny, Wayne Bequette, Yang Zhang, Zoltan Nagy, Moritz Diehl, Juergen Hahn, and Roger Aarenstrup are gratefully acknowledged.